

OWNER'S MANUAL : HOBIE WILD CAT**HOBIE CAT WILD CAT**

OWNER'S MANUAL : HOBIE WILD CAT

Welcome in the Hobie Way of Life !



Photo Pierrick Contin

Congratulations on the purchase of your new HOBIE CAT and welcome to the HOBIE sailing family. Your Hobie Cat is a long life boat.

The Hobie Wild Cat is a F18 Catamaran and is destined to experienced sailors.

We offer this manual as a guide to increased safety and enjoyment of your new boat. The purpose of this publication is to provide easy, simple and accurate instructions on how to get your Hobie ready for the water. Please read them carefully and familiarize yourself with the boat and all of the parts spread before you.

Whether you are a new sailor or a veteran of many years, we recommend that you read this thoroughly before your first sail and TRY IT OUR WAY FIRST! If you are new to sailing, this manual alone is not intended to teach you how to sail. There are many excellent books, videos and courses on the safe handling of small sailboats. We suggest that you contact your local sailboat dealer, college or Coast Guard Auxiliary for recommendations.

Watch for overhead wires whenever you are rigging, launching, sailing or trailering with the mast up. CONTACT OF THE MAST WITH POWER LINES COULD BE FATAL! Be certain that the rigging area and the area that you will be sailing in are free of overhead power lines. Report any such power lines to your local power authority and sail elsewhere.

We take pride in presenting this Hobie Cat to you and hope that you'll take as much pride in owning her.

Fair winds and good sailing!
Hobie Cat Europe

OWNER'S MANUAL : HOBIE WILD CAT**Table of content**

Pages	Description
4	Description of the boat
5	Safety advices
6	Further information
7-8	How to use your Hobie
9	Dealer's receipt
10	Warranty conditions
	ASSEMBLY MANUAL
11	List of the necessary tools
12-17	List of the parts
18	Hull / Crossbar assembly
19-21	Trampoline Assembly
22-26	Preparing the past
27-30	Stepping the mast
31	Mast rotation
32	Installation of the boom
33-35	Assembling the spinnaker kit
36-39	Hoist the main sail
40-42	Hoist the jib
43	Hoist the spinnaker
44-45	Rudder assembly
46	Tiller crossbar & stick assembly
47	Tuning guide : daggerboards, Cunningham, rotation, mast rake
48	Tuning guide : tensioning the rig
49	Contact

APPENDIX:

- ◆ ILLUSTRATED PART GUIDE
- ◆ BUILDER'S CERTIFICATE

**KEEP THIS MANUAL IN A SAFE PLACE AND GIVE IT TO THE
NEW OWNER IF YOU SELL YOUR BOAT**

OWNER'S MANUAL : HOBIE WILD CAT

Description of the boat

Length m :	5,51
Width m :	2,60
Mast height m :	9,00
Weight kg :	180
Main sail area m ² :	17
Jib sail area m ² :	4,15
Spinnaker area m ² :	21
Maximum load kg :	240
Crew number :	3
Homologation EC n° :	
Module :	Abis
Category :	C/D
Hull construction :	Sandwich polyester

Builder :

Hobie Cat Europe
 zi Toulon Est, BP 250
 83078 Toulon cedex 9 France
 Tel +33 (0)494 08 78 78
 Fax +33 (0)494 08 13 99
 E-mail : info@hobie-cat.net
<http://www.hobie-cat.net>



Builder's plate



The boat identification number is engraved on the transom of the boat. Example



Immatriculation is mandatory (see governmental web sites for procedure).

The building of Hobie Cat is made according to the following ISO norms :

- ISO 12215-1:2000 Hull construction
- ISO 12217:2000 Stability and buoyancy assessment and categorization
- ISO 10087:1995 Hull identification and coding system
- ISO FDIS 14945 Builder's plate
- ISO 10240:1995 Owner's manual
- ISO FDIS 8666 Small crafts main data

OWNER'S MANUAL : HOBIE WILD CAT

Safety advices

- Whether on land or on the water, watch for overhead power lines. Contact with power lines can cause serious injury or death.
- DO NOT sail while under the influence of alcohol and/or drugs
- Only sail in conditions in which you feel comfortable and where you feel confident that you can safely sail the boat. Never go out in conditions beyond your ability.
- Everyone on board should wear a life jacket at all times.
- If you are in the water, remain in contact with the boat, even if it is capsized. A sailboat can drift away faster than a person can swim.
- Never sail without a righting line.
- Wear appropriate clothes. Wear a wet suit or dry suit in cold weather or cold water conditions.
- Protect yourself against heat and sun.
- Learn the right of way rules and when in doubt, give way to others.
- When not sailing, always keep the boat pointed into the wind whether in the water or on the beach.
- Read the instruction manual carefully.

OWNER'S MANUAL : HOBIE WILD CAT**Further information**

Hobie Cat owners are organised in a world-wide class association :

The IHCA (International Hobie Class Association).

For Europe, you can contact the EHCA (European Hobie Class Association).

Visite their web site :

<http://ehca.hobieclass.com>

to find contact details for your country.

OWNER'S MANUAL : HOBIE WILD CAT

How to use your Hobie

Before sailing check the following points :

1/ Install the drain plugs (if any) – do not overtighten, hand tight is sufficient. Overtightening may cause the drain plug flange to distort and cause leakage.

2/ Tension the rig. This can be accomplished by having your assistant hang from the trapeze or you can use mainsheet tension on one side at a time so that you can adjust the shroud position in the side stay adjusters.

3/ Fit the daggerboards into the daggerboards wells.

4/ Check all fastenings :

- Mast tang shackles and shrouds (to prevent the mast to fall down)
- pins and trapeze rope locks (to prevent falling out in the water if the trapeze is not well fastened)
- pins and spring rings on the forestay and shrouds (to prevent the mast to fall down)
- spring rings on the rudder pins (to prevent losing the rudder assembly in case of capsizing)

Transport and launching

In order to avoid hull damages :

- Always use a dolly to transport your Hobie Tiger on the beach (even if it is sand beach) and for launching. Step into the water with the dolly and once the cata is afloat take out the dolly.

- DO NOT BEACH. Beaching, even smoothly, may damage the hulls. use your beach dolly to take the boat out of the water.

- For towing, always use an homologated road trailer with cradles.

OWNER'S MANUAL : HOBIE WILD CAT

How to use your Hobie

Launching the boat

Launching the boat is easiest when the boat can be pointed into the wind to keep it de-powered and floated into deep enough water to lower the rudders. It is possible to launch in shallow water with the rudders partly up. Try not to steer with too much force on the rudders until you lock them in the down position. Keep the sail loose and trimmed out completely until you can power up and steer away from any obstacle.

Righting the boat

If you tip the boat over, in order to avoid the mast from sinking under the hull, one of the crew must rapidly climb on the hull that remains on the water. In the meantime, the other crew uncleat all the lines and sheets.

It is not necessary, but it is easier, to right the boat when the bow and the mast are pointed into the wind. There will be less resistance and better control in this position.

Skipper and crew stand up on the hull. Using the righting line, skipper and crew pull the righting line that is against the upper hull and



hold the line while slowly leaning back away from the trampoline. As the mast and sail lift out of the water, drop down to your knees then into the water. Hold on to the crossbar near the hull that you were

standing on.

Be well aware of the hull and crossbar coming down over your head. Holding the crossbar or righting line will also insure that you remain with the boat when it is righted. Climb aboard and continue sailing

Storage and maintenance

Hobie Cat does not recommend leaving your Hobie in the water on a mooring. Accelerated wear to the boat and rigging will be experienced. Damage to the hull material is possible. Limitation of the mast rotation and tensioning of the rigging are required to lessen this wear. Inspect rigging often and tape rigging rings and shackles to prevent loosening.

After sailing, it is recommended to wash the hulls to remove the salt. Also remove the sails and wash them before storing them.

There is one plug in the rear of each hull. These plugs are used to drain the hulls. The plugs should be in place before sailing. Remove the plugs after sailing to drain any water that may have leaked into the hulls. It is best to travel with and store the boat with the plugs removed to allow for pressure changes due to heating, cooling, and altitude changes. This will prevent warping of the hull surface.



OWNER'S MANUAL : HOBIE WILD CAT**Dealer's receipt**

Your Hobie Cat dealer :

(stamp)

Your dealer is our representative and will bring you all necessary assistance in order to solve problems you may encounter.

As soon as you become owner, please date and sign this receipt (below) and give it to your dealer to be covered by our warranty.

Please carefully read the warranty conditions written hereafter in this manual.

**Please carefully and thoroughly read this manual. Keep it in a safe place
and give it to the new owner if you resell your Hobie.**

OWNER'S MANUAL : HOBIE WILD CAT

Warranty conditions

This warranty applies to customers of Hobie Cat Europe. The boat is warranted to the original retail customer for one year from the date of retail purchase against defects in materials and workmanship.

The spare parts are warranted for one year.

The components coverage applies only to the original retail customer. The warranty is not transferable.

In no case, the repairs made will extend the initial date of the warranty, except for any replacement or repaired parts.

The Warranty Registration Card is required by law for use in the event of a product problem notification.

The warranty is only effective if the boat is sold by an authorised Hobie Cat dealer.

What is covered?

Replacement parts and labour. According to the decision of Hobie Cat Europe, the dealer will make the repairs himself or through an external contractor, after presentation of an estimate and written agreement from HCE. The dealer will be then reimbursed after presentation of the invoice. The warranty covering these repairs will no longer be at HCE's charge but at the contractor's charge.

What is not covered?

- normal wear and discoloration
- Transport charges to or from the dealer's shop to the client
- charges occurred in case of an on-the-spot repair.
- Damages caused by abuse or failure to perform normal maintenance (see assembly manual), by a defective or abnormal use or by a bad storage.
- Discoloration, blistering or grazing of gelcoat caused by boat being moored or stored in salt or fresh water.
- The boat is not covered under warranty if the boats are hired or placed in commercial service.
- Hobie Cat Europe is not responsible for boat damage as a result of adding additional blocks to the original manufacturer's sheeting arrangement.
- Any other expenses: CONSEQUENTIAL DAMAGES, INCIDENTAL DAMAGES, OR INCIDENTAL EXPENSES, INCLUDING DAMAGE TO PROPERTY.

How to obtain warranty performance within 30 days of discovering the defect:

Bring your boat to the nearest authorised Hobie Cat Europe dealer (a list of the dealers is available at HCE). Be sure to take proof of date of retail purchase (invoice). All payments for in-

warranty expenses shall be made by Hobie Cat Europe to the Hobie Cat Europe dealer and not to the customer.

Implied warranties:

IMPLIED WARRANTIES, INCLUDING THE IMPLIED WARRANTIES OF MERCHANTABILITY AND FITNESS FOR A PARTICULAR PURPOSE, SHALL BE NO LONGER THAN THE DURATION OF THIS EXPRESS WARRANTY.

Hobie Cat Europe makes no express warranties in addition to this limited warranty. Hobie Cat Europe's dealers have no authority to make any warranties on behalf of Hobie Cat Europe in addition to or inconsistent with those stated herein. To the extent any provision of this warranty is prohibited by federal, state, or municipal law and cannot be pre-empted, it shall not be applicable.

HOW IT WORKS?

It is essential that for each sold boat, the warranty card be completely filled in, signed by the dealer and the customer, and that the copy for Hobie Cat Europe be returned to the factory within 8 days of boat delivery.

For all claims the warranty department must be contacted. The final decision regarding warranty claims lies with this service.

SPECIAL NOTES:

- All warranty transactions will be handled through the claiming dealership and not directly with the customer.
- Hobie Cat dealers are responsible for proper diagnosis and completion of all warranty claims.
- If in doubts about warranty coverage of a particular problem, contact the Warranty department first.
- Warranty work may be carried out by an authorised dealer other than the original seller of the boat, however for all warranty requests it is mandatory to fax or mail a copy of the completely filled out warranty card which must have been registered immediately following delivery to the customer.
- As warranty work is registered following the information of the warranty card, it is mandatory that the card be filled out in detail in all the boxes. Failure to cite a hull, sail, or serial numbers on the warranty will make claims impossible to process. en détail toutes les cases. L'oubli d'une coque, d'une voile ou d'un numéro de série rendra toute réclamation impossible à traiter

ASSEMBLY MANUAL : HOBIE WILD CAT**List of the necessary tools**

Driller

Lubricant

Tape measure

Drill \varnothing 8

Allen key supplied

Screw driver

Wrench

Adjustable wrench

ASSEMBLY MANUAL : HOBIE WILD CAT**List of the parts / References**

Your Hobie Wild Cat is delivered in 5 parcels :

1. Right hull (18756282)
2. Left hull (18756180)
3. Parcel n° 1 including
 - Front crossbar (18762500) with the trampoline (18725800) mounted
 - Rear crossbar (18762600)
 - Boom (18712800)
 - Tiller crossbar (18762260)
 - Rig bag (18780300)
 - Rope bag (18770400)
 - Wire bag (18760500)
4. parcel n° 2 including
 - Centreboards (18750910) x 2
 - Right rudder assembly (18762160)
 - Left rudder assembly (18762150)
 - Tiller extension (99502360)
 - Mainsail
 - Jib
 - Spinnaker
 - Spi trumpet (99267755) + spi bag (99267527)
5. Spi pole (18770300)



ASSEMBLY MANUAL : HOBIE WILD CAT

List of the parts - Ropes



N°	Description	Reference	Quantity
1	Rear trampoline lacing line	18770420	1
2	Jib halyard	18770417	1
3	Mast rotation line A	18770416	2
4	Degressive spinnaker halyard	18770410	1
5	Jib cunningham B	18770408	1
6	Jib car bordering line	18770419	1
7	Main cunningham (mast cleat)	18770504	1
8	Jib cunningham A	18770407	1
9	Righting line	18070414	1
10	Self tacking jib line	18770402	1
11	Mast rotation line B	18770425	1
12	Trumpet support line	18070431	1
13	Pole support line	18070420	1
14	Spinnaker sheet	18770409	1

ASSEMBLY MANUAL : HOBIE WILD CAT
List of the parts – Rigging parts

N°	Description	Reference	Quantity
1	Crossbar fixation bolts	99220485	8
2	Aluminium washer	99220052	8
3	Teflon washer	99220290	8
4	Block H417	99500495	1
5	Stop ball	99500103	2
6	Shackle Ø4	99220036	2
7	Wrench BTR8	99220060	1
8	Jib blocks	99500478	2
9	Shackle Ø 6	99220035	2
10	Shroud adjuster Stay Master	99180060	2
11	Spi winch block	99501575	2
12	Self welding tape	99316037	1
13	Snap shackle	99500435	1
14	Boom triple block	99501580	1
15	Degressive mainsheet rope	18770401	1
16	Triple winch block with cleat	99501585	1

ASSEMBLY MANUAL : HOBIE WILD CAT
List of the parts – Wire set

N°	Description	Reference	Quantity
1	Spreader bar kit V2	18760300	1
2	Left adjustable spreader wire	18760565	1
3	Shrouds	18780400	2
4	Right spreader wire	18760560	1

.../...

ASSEMBLY MANUAL : HOBIE WILD CAT
List of the parts – Wire set

N°	Description	Reference	Quantity
5	Bridle	18770500	2
6	Bolt with eye	99220134	1
	Nylstop nut \varnothing 6	99220019	1
7	Stay adjuster	99220033	1
8	Single Micro block	99500478	2
9	Jib halyard	18770418	1
10	Forestay + Pigtail	18760530	1
11	Shackle \varnothing 8	99220058	1
12	J&H trapeze handles	99500037	2
13	Pole single block	99500114	2
14	Shackle \varnothing 4	99220036	5
15	Gooseneck hinge	14070351	1
16	Trapeze wires	18760570	2
17	Mast cam cleat for spi halyard	99500140	1
18	Single carbo block	99500850	1
19	Shackle \varnothing 6	99220035	1

ASSEMBLY MANUAL : HOBIE WILD CAT**List of the parts – Spi trumpet**

N°	Description	reference	Quantity
1	Spinnaker trumpet soft	99267755	1
2	Spinnaker soft bag	99267535	1

ASSEMBLY MANUAL : HOBIE WILD CAT**Hull and crossbar assembly**

1. Place the hulls parallel to each other with the insides face down on the ground. Take the right hull and turn it right side up, one person should stand astride it to hold it in place.



2. Take the front crossbar (the one that has the martingale and the trampoline pre-assembled). Turn it so that it enters into its socket, being careful to have the trampoline towards the back.



3. Insert the two bolts and washers in the order shown in the photo. Tighten gently without forcing. Now take the left hull, and proceed in the same way as for the right hull. Do not tighten completely
4. Position the back crossbar on the right-hand side. Insert the bolts and washers as for the front crossbar. Repeat the same action on the left-hand side.



5. Once that the frame is assembled, tighten the whole assembly.



It is recommended to check the tightness of all screws, bolts and the forestay of the martingale after the first navigation, and then at regular intervals.

ASSEMBLY MANUAL : HOBIE WILD CAT**Trampoline assembly**

1. Attach the trampoline onto the front crossbar as indicated on the photo.



2. and hold in place with a bowline knot.



3. On the back right-hand side, bring the trampoline up along the cord. Make a loop which will be, after tension, completely hidden inside the seam of the trampoline.



4. Pass the free end through the ring on the back crossbar and bring it back through the loop that you have just made.



5. Then back through the ring

.../...

ASSEMBLY MANUAL : HOBIE WILD CAT**Trampoline assembly**

6. And again through the loop.



7. Once more through the ring



8. Then pass through the eyelet of the trampoline



9. Tie a knot to stop the cord at the ring as shown in the photo.

10. Repeat the same procedure on the other side.

.../...

ASSEMBLY MANUAL : HOBIE WILD CAT**Trampoline assembly**

11. Unroll the trampoline towards the back making sure that the fiber glass rod is in place and centred in the band at the back of the trampoline.

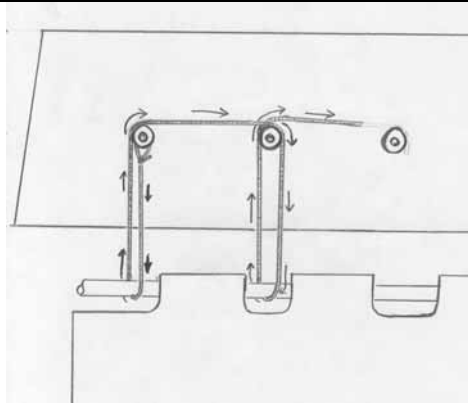

12. Take the back trampoline lacing and lace as shown the diagram : attach the end to the first lacing button, take the lace down and around the rod, bring up again around the first lacing button, pass over the second lacing button, down around the rod and back over the second lacing button, and continue to the end of the crossbar.



13. Correct lacing



1. Finish with a half-hitch knot.

ASSEMBLY MANUAL : HOBIE WILD CAT

Preparing the mast

Place the mast onto supports (trestles) if possible at about 80 cm from the ground, so as not to strain your back while rigging the mast, leaving enough room to go all the way around the mast.

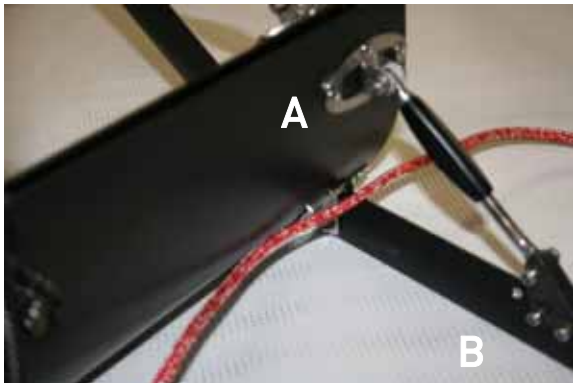

1. Installation of the spreaders

Take the spreader kit and screw the two spreaders in place as shown in the photo.

2009 model: attach the black fixed part (A) with the nut and bolt onto the stainless steel fitting of the mast and attach the adjustable part (B) with the axle and the split ring on the aluminium fitting.

2010 model : The two parts, A and B are attached with the nuts and bolts delivered in the plastic bag with the kit.

Cover the nut and bolt (or the axle and split ring) that fix the part B with self-welding tape.

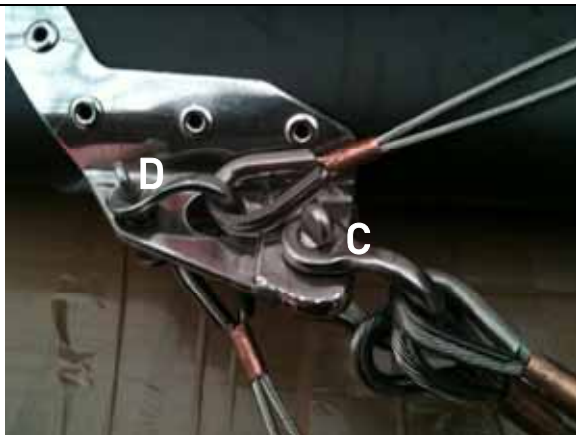

2. Wiring mast fittings

Take the shackle n° 8 (C) at the end of the forestay cable, remove the shackle, insert a shroud on each side of the forestay, and fix the shackle to the bottom hole of the rigging fitting at the top of the mast.

BE CAREFUL which way the forestay is installed : The strap (E) should be against the mast.

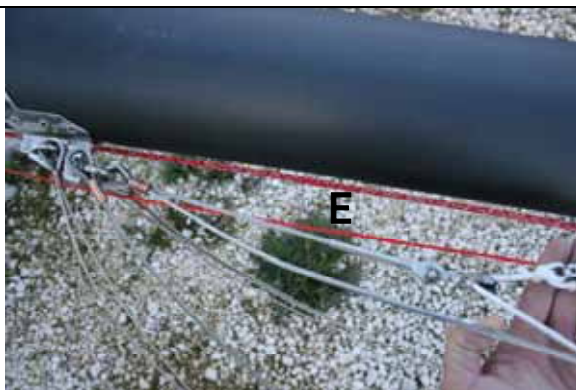

Take the trapeze cables. Remove the shackle n° 6 (D) which joins them, insert them into the second hole in the rigging fitting and pass each side of the close end thimbles on the trapeze cables. Pass the shackle through the first hole of the rigging fitting and fix in place with the pin.

.../...

ASSEMBLY MANUAL : HOBIE WILD CAT**Preparing the mast****3. Installation of the spinnaker halyard**

Insert the thin part of the spinnaker halyard into the spinnaker turret cleat (F) at the base of the mast.

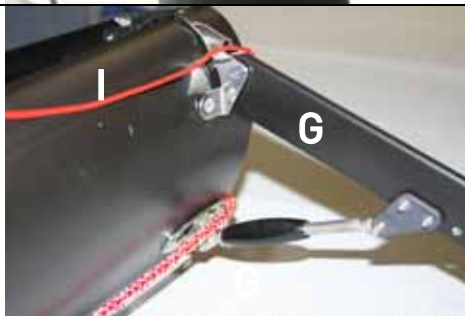

Take it up the mast passing inside the left spreader (G), pass through the pulley at the top of the mast (H), back down along the mast (I) and fix it on the turret cleat for the moment (F) without passing back through spreader bars.

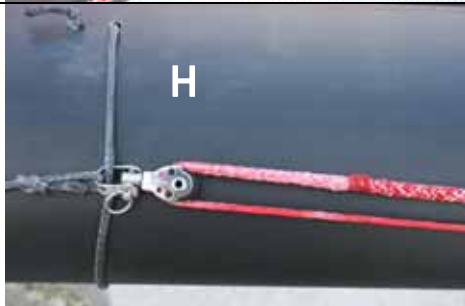
**4. Installation of the jib halyard**

The jib halyard is pre-assembled on the strap. Pass the jib rigging halyard (J) through the pulley situated at the end of the jib halyard and attach as shown in the photo. Attach the other end to the spinnaker turret cleat for the moment (F).



.../...

ASSEMBLY MANUAL : HOBIE WILD CAT**Preparing the mast****4. Installation of spreader cables**

Unroll the spreader cables.

Take the left cable and insert it into the slot at the base of the mast.



bring it out of the bottom of the mast and screw to the base of the mast foot.
Leave the other end on hold.



Take the right adjustable cable, unscrew the bottom part and repeat the same operations as for the first cable only this time on the right side.



The two cable are now screwed to the base of the mast foot.



Now just put the mast foot into the mast base.

.../...

ASSEMBLY MANUAL : HOBIE WILD CAT**Preparing the mast**

Attach the left cable to the fitting situated on the left-hand side above the spreaders.



Slip the spreader into the corresponding slot of the left spreader, taking care that the black plastic disk is above the spreader.



Repeat the same for the right cable, being careful to screw the two parts of cable together.



Adjust the tension with the help of the adjusting screw on the right spreader cable to straighten the mast.



Once that the mast is completely straight, put tension on the two cables under the mast foot with a spanner.

.../...

ASSEMBLY MANUAL : HOBIE WILD CAT

Preparing the mast



Using the small pieces of fine cable provided, secure the ends of the spreaders. Pass through the hole at the end of the spreader, and on one side of the spreader roll two or three times around the spreader cables. Do the same the other side, cut off any pieces that are too long, and be careful that they are tightly rolled so that there is no risk of tearing the sail.



Once that the assembly is finished cover with tape.

ASSEMBLY MANUAL : HOBIE WILD CAT

Stepping the mast



CAUTION DANGER – ALUMINIUM MAST

Keep away from electric cables



Place the mast on the trampoline, the mast base facing its support on the front crossbar.

1. Installation of the bridles

Take the bridles from the cable bag and fix to the bridle fittings at the front of the hulls.



2. Installation of the shouds•Connect the shroud cables the the Staymasters that are in the rigging bag. Fix the Staymasters on the eye bolts on each hull. Unscrew the serrated adjustment roller of the Staymasters to the maximum.

3. Raising the mast

Before raising the mast, remove the plastic bag that is fixed to the jib rail and which contains the Cunningham system and place it on the trampoline.



It is recommended to have two people to raise the mast : One in front of the front crossbar (A) holding the base of the mast, the other at the back (B) holding the mast head. (A) takes one of the trapeze cables to relieve the weight of the mast, being careful that the base of the mast remains encased on the crossbar.



(B) advances along the mast while raising it. As the mast raises, (A) moves back little by little, pulling on the trapeze in order to help (B) raise the mast.

.../...

ASSEMBLY MANUAL : HOBIE WILD CAT

Stepping the mast

	<p>Position once the mast is raised</p>
	<p>Once that the mast is upright, while (B) pushes the mast forward, (A) connects the shroud to the stay adjuster.</p>
	<p>4. <u>Installing the trapezes</u></p> <p>Fix the shackle to the trapeze wire.</p> <p>Make a bowline knot between the shock cord that comes out of the front crossbar and the trapeze line.</p>
	<p>Front trapeze shock cord (A). Spare trapeze shock cord (B).</p>
	<p>Place of the rear trapeze line . Mount the same way as for the front trapeze.</p> <p style="text-align: right;">.../...</p>

ASSEMBLY MANUAL : HOBIE WILD CAT**Cunningham / Righting line**

1. Take the cam cleats that are pre-assembled on the end of the Cunningham attached to the front crossbar.



2. Using the pins and split rings, install the Cunningham cam cleats onto the support plates at the bottom of the mast.



3. Lace the small pulleys onto the mast foot, taking care of the order in which they must be placed.



4. Pass through the next hole

.../...

ASSEMBLY MANUAL : HOBIE WILD CAT**Cunningham / Righting line**

5. Pull on the cord while holding the pulley to pass all of the loose cord through



6. Pull through tightly and finish by a knot that can be easily undone.



7. It should look like this when the assembly is finished.



8. Install the righting cord around the martingale forestay. Lift the free end of the cord onto the trampoline through the eyelet situated at the mast foot and stock the surplus cord in the trampoline pocket.

ASSEMBLY MANUAL : HOBIE WILD CAT**Mast Rotation**

Take the simple pulley that is on the n° 4 shackle in the rigging bag and fix it to the end of the rotation arm.



Take the mast rotation cord B from rope bag. Detach one of the pulleys.

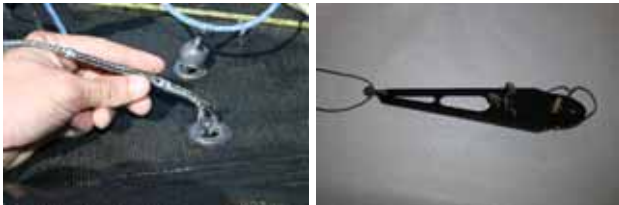

From under the trampoline, pass the end of the cord through the eyelet facing the rotation arm, then into the pulley already assembled, then back down under the trampoline through the eyelet and then put the pulley back onto the end.

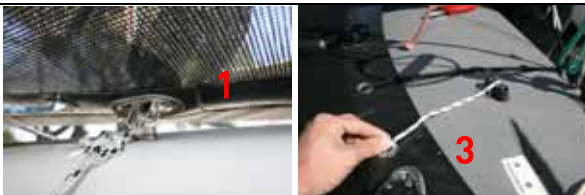

Take the mast rotation cord A from the rope bag. Starting with the right hull attach one end to the pad-eye (1), under the trampoline lead it through the right-hand pulley (2), out through the eyelet facing the cleat on the hull and bring to the cleat (3).

Repeat the operation for the left hand side



ASSEMBLY MANUAL : HOBIE WILD CAT

Installation of the boom



Connect the boom on the mast

using the gooseneck hinge,

the pin and the split ring.

ASSEMBLY MANUAL : HOBIE WILD CAT

Spinnaker kit assembly



1. Installing the spi pole

Connect the pole to the front crossbar



using the pin and split ring.



Attach the front bridles and make sure the the pulley at the end of the pole is facing upwards towards the sky.



Put on the central tension rope without tightening for the time being. It will need to be tightened after the tension has been put on the shrouds and it has been determined which hole for the forestay.

.../...

ASSEMBLY MANUAL : HOBIE WILD CAT**Spinnaker kit assembly****2. Installation of the spinnaker trumpet**

Position the spinnaker trumpet on the boom taking into consideration two parameters :

- Once the sock is taut it should be at about 10 cm behind the front crossbar,
- The mouth should be perpendicular to the pulley at the end of the boom.

Drill the boom with a 8 mm bit through the holes of the trumpet; screw to the boom with the screws that are supplied.



The sock should be taut with the least folds possible.



Take the holding rope of the trumpet and make a loop around the spinnaker boom, hold in place with a bowline knot, then tighten the end through the opening of the trumpet and bring to be attached to the bridle support on the hull.

.../...

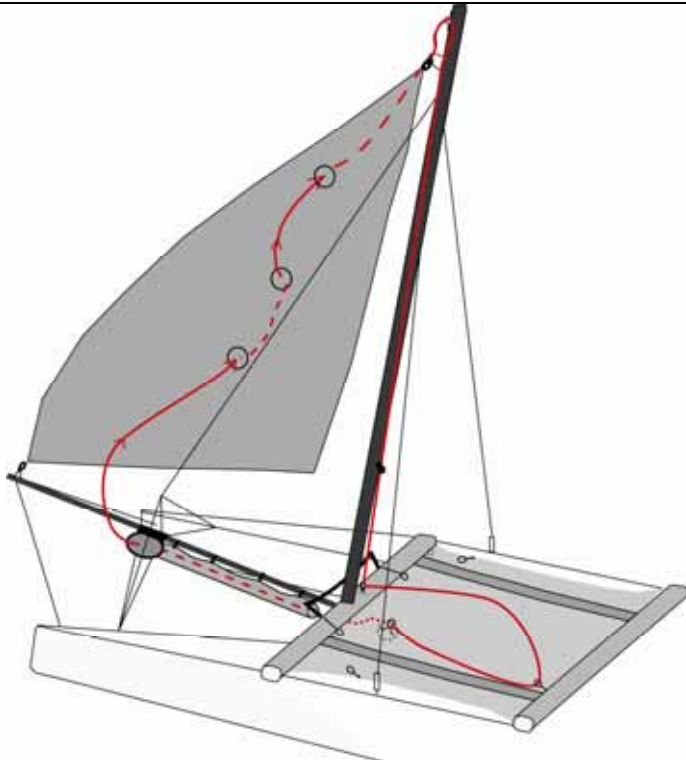
ASSEMBLY MANUAL : HOBIE WILD CAT**Spinnaker kit assembly****3. Spinnaker halyard circuit.**

Pick up the spinnaker halyard that was left waiting on the halyard cleat of the mast.

Follow the diagram for the halyard circuit :

Take the spinnaker halyard down from the cleat on the front crossbar then, into the pulley near to the rear crossbar. After, take it through the pulley on the trampoline and under the trampoline, through the sock and out of the trumpet. Fix it on to the spi pole for the moment.

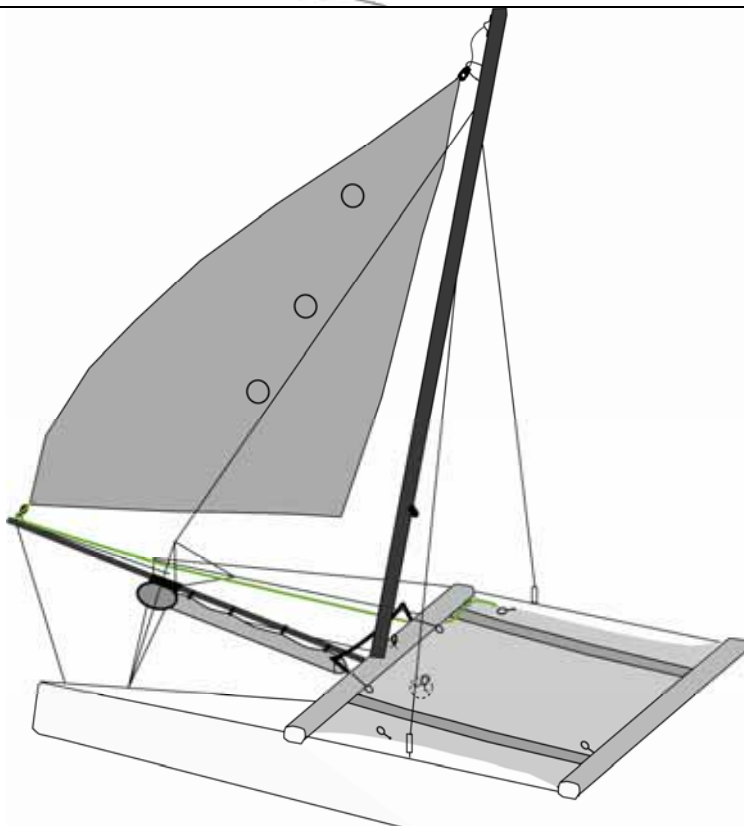
**4. Spinnaker tack**

Take the spinnaker tack line which is fixed under the front crossbar and pass through the pulley at the front of the boom, tie a knot while waiting to fix it to the spinnaker.

ASSEMBLY MANUAL : HOBIE WILD CAT

Rigging the boat : Main sail

Rigging tension

Before hoisting all of the sails, the rigging tension must be adjusted. Please read the tuning guide at the end of this manual. Tighten the central tension of the spinnaker pole.

Unfold the main sail on the trampoline and insert the battens into their sleeves. The battens are numbered (1 to 7) from the smallest N° 1 (at the top of the sail) to the longest N° 7 (at the bottom of the sail). Attach the ends of the battens with the laces as in the photo.



1. Battens
Pass the two ends of the laces into the hole in the batten.



Then through the eyelet on the sail from the outside.



Tie a reef knot over the laces.



Tighten and slip the two ends into the batten sleeve.

.../...

ASSEMBLY MANUAL : HOBIE WILD CAT

Rigging the boat : Main sail



2. Hoist the main sail

Undo the ends of the halyard, make a knot at the end of the halyard that comes out of the base of the mast.



Take the other end and pass it through the small ring from the back as in the photo.



Tie a figure of eight knot.



Introduce the luff of the main sail into the opening of the mast track and hoist the mainsail by pulling on the halyard while carefully guiding the luff. Go passed the hook and let it slide it will hook automatically. To lower the mainsail, pull on the halyard , turn the mast to the side to unhook and pull on the sail to lower.

.../...

ASSEMBLY MANUAL : HOBIE WILD CAT**Rigging the boat : Main sail****3. Mainsheet system**

Insert the end of the boom into the strap of the clew point of the mainsail.
Fix the shackle to the metal ring of the mainsail.



Take the mainsheet assembly (already mounted) from the rigging bag and attach the snap hook to the strap of the mainsail, under the boom.



Fix the pulley winch on the carriage using its shackle. Pass the mainsail sheet into the carriage cleat, separate the two parts and pass them in the cleats behind the rear crossbar, as in the photo.

.../...

ASSEMBLY MANUAL : HOBIE WILD CAT

Rigging the boat : Main sail



4. Cunningham

Attach the Cunningham pulleys to the tacking point on each side of the main sail as shown in the photo.



Take the Cunningham ropes from the rope bag. Insert one of the ropes into the cleat on the right on the mast,

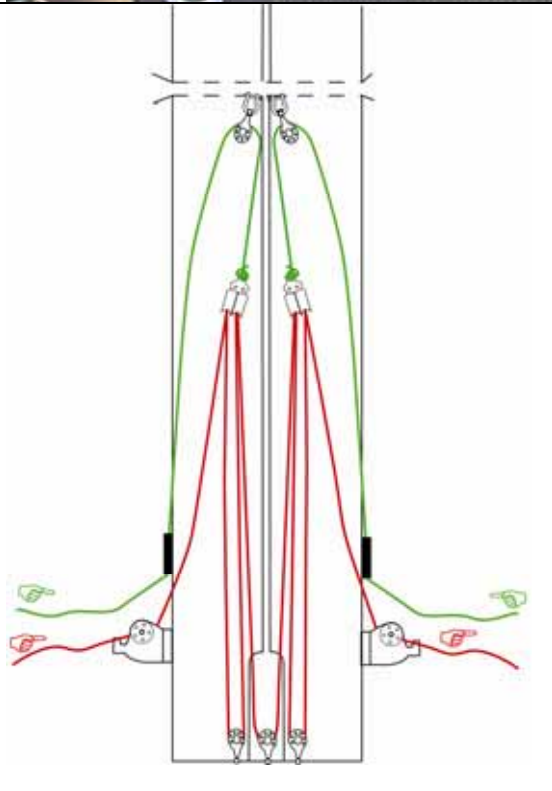

pass it through the pulley on the right of the mainsail

and take it down to be attached to the top of the right double pulley of the Cunningham system that is pre-assembled.

Do the same thing on the other side with the other rope.

ASSEMBLY MANUAL : HOBIE WILD CAT**Rigging the boat : Jib**

1. Attach the head of the using the shackle positioned on the white halyard rope.



2. Position the jib so that the halyard rope and forestay are inside the zip. Pull on the halyard rope to hoist the jib. Close the zip carefully as you go.



3. Attach the jib tacking point to hole in the eye bolt with the help of a large shackle.

.../...

ASSEMBLY MANUAL : HOBIE WILD CAT**Rigging the boat : Jib**

4. Once that the jib is hoisted, replace the yellow halyard by the jib Cunningham rope (B).



5. Pass through the eye, then into the pulley that comes out of the jib zip (in the place of the yellow halyard) back down and tie a knot on the large shackle.

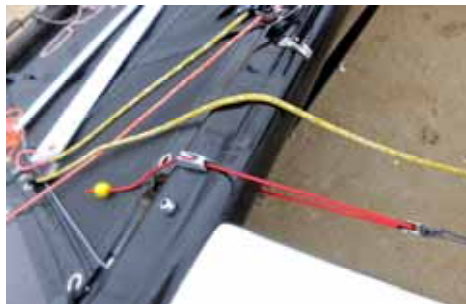

6. Take the end of the cunningham line and pass it through the pulley attached at the fixing point of the left bridle. Attach to the end a small pulley.
7. Take the Cunningham rope A from the rope bag. Attach one end on the martingale under the hull. Pass the other end through the pulley and back to the cleat on the front crossbar.

.../...

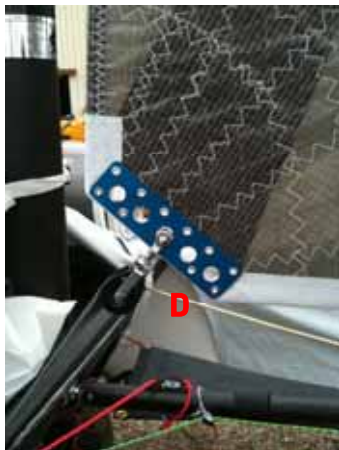
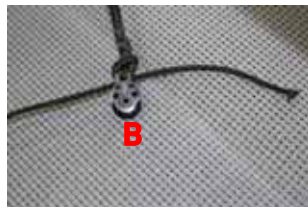
ASSEMBLY MANUAL : HOBIE WILD CAT**Rigging the boat : Jib**Jib sheet

The jib sheet is pre-mounted on the front crossbar.

Attach the spectra line on the block that is pre-mounted on the jib sheet (A)

Lead the spectra line through the block that is fixed on the spi pole (B).

Then lead it through the carbo pulley attached to the traveller car on the self-tacking track (C).

Then passes through the carbo block of the jib clew (D) and then ties off to the carbo block mounted on the traveller car.

Tie a bowline knot through the hole in the middle of the pulley.

ASSEMBLY MANUAL : HOBIE WILD CAT**Rigging the boat : Spinnaker****1. Spinnaker blocks**

Fix the spinnaker blocks (from the rigging bag) onto the trampoline, put the trampoline against the pad eye and pass the rope through the eyelet of the trampoline onto the pad eye to fix the block.

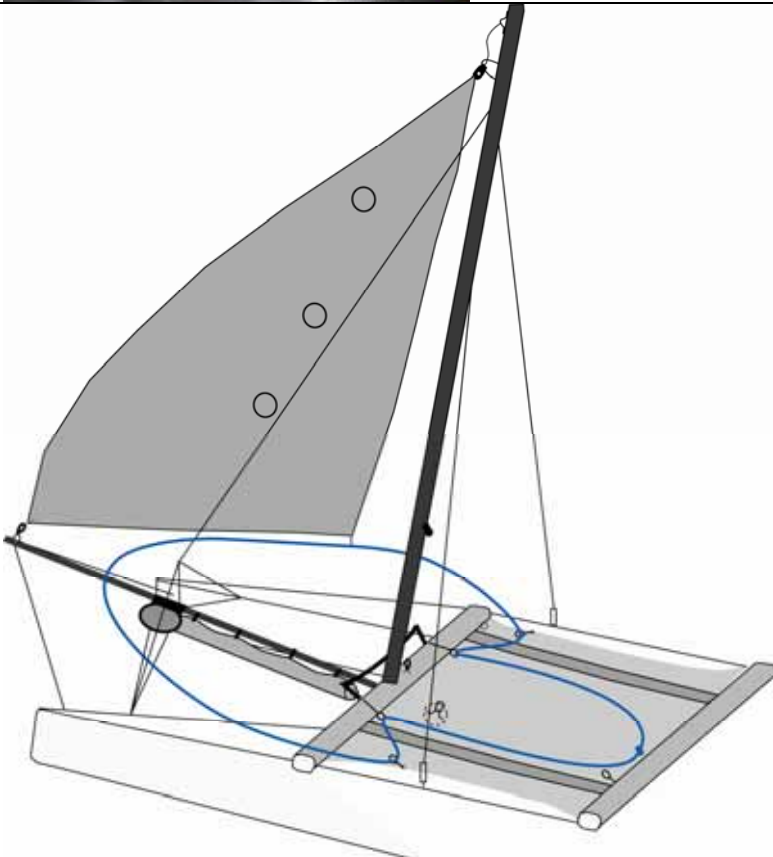
**2. Final assembly.****3. Ecoute de spi**

Fix the strap (that is in the middle of the jib sheet) to the sheet point by a bowline knot – follow the diagram opposite and attach the two ends together.

ASSEMBLY MANUAL : HOBIE WILD CAT**Rudder assembly**

1. Take the pintle and insert it through the rudder arm and the top gudgeon.



2. Place the washer between the gudgeon and the rudder casting.



3. Rudder in the 'up' position.

.../...

ASSEMBLY MANUAL : HOBIE WILD CAT**Montage des gouvernails**

4. Rudder in the 'down' position.



5. Engage the round plastic part into its cavity on the rudder arm.



6. Fix the elastic over the metal pin.

ASSEMBLY MANUAL : HOBIE WILD CAT**Tiller crossbar & extension**

7. Assemble the tiller system as in the photo.



8. Fix the tiller extension in the middle of the tiller crossbar.

ASSEMBLY MANUAL : HOBIE WILD CAT

Tuning guide : Daggerboard, Cunningham, rotation, mast rake

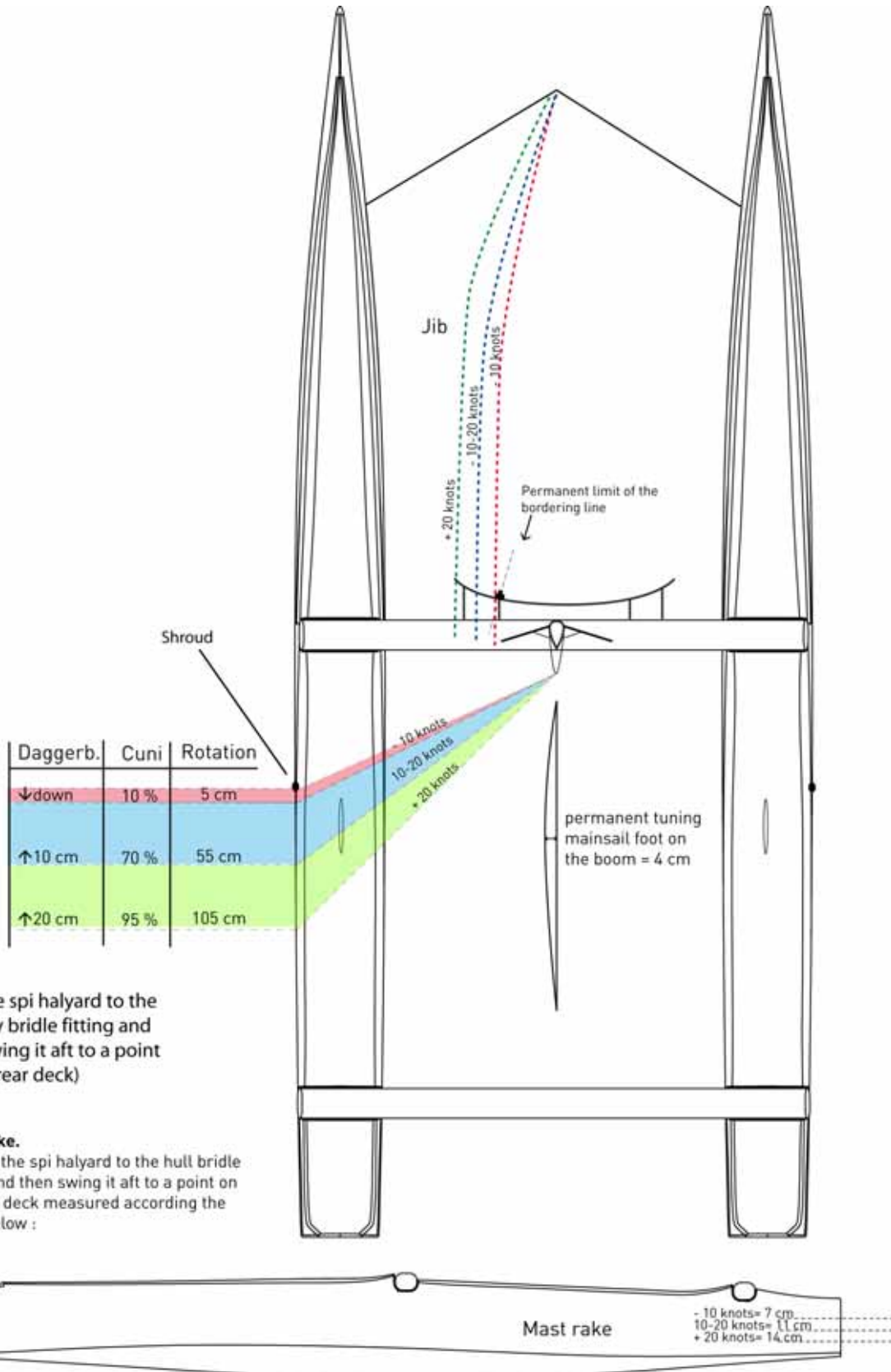

take the spi halyard to the forestay bridle fitting and then swing it aft to a point on the rear deck)

Mast rake.
Tension the spi halyard to the hull bridle fitting and then swing it aft to a point on the rear deck measured according the chart below :

ASSEMBLY MANUAL : HOBIE WILD CAT
Tuning guide : rig tension

Crew weight	Shroud	Spreader wire tension	Opening of the spreader bar	Mast rotation (in°)	Daggerboards height (cm)	Cunningham tension (% of your max power)
	10 knots or less					
140-150 kg	21-24	37	55	50	0	10
150-160kg	20-24	37	45	50	0	10
160kg +	18-22	37	35-40	50	0	10
	10/20 Knots					
140-150 kg	24-28	39-41	55	40	10	30-70
150-160kg	24-30	39-41	45	40	10	30-70
160kg +	25-30	38-41	35-40	40	10	30-70
	20 knots and more					
140-150 kg	27-30	39-41	55	30	20	95
150-160kg	28-30	39-41	45	30	20	95
160kg +	28-30	39-41	40	30	20	95

Tensiometer Loose and Co

ASSEMBLY MANUAL : HOBIE WILD CAT

Contact



HOBIE CAT EUROPE SAS

ZI Toulon Est BP 250

83078 Toulon cedex 9

Tel : +33 (0)494 08 78 78 – Fax : +33 (0)494 08 13 99

Email : info@hobie-cat.net – <http://www.hobie-cat.net>